



SOCIALIZING



SWINGING



INFORMATION ABOUT THE PRODUCT

Dimensions	100 x 278 cm
Safety zone	750 x 235 cm
Safety zone area	18 m ²
Overall height	231 cm
Free fall height	133 cm
Amount of users	4
Product complies with EN 1176-1:2017-12	YES
Availability of spare parts	YES
Age range	3-12

According to EN 1176-1:2017-12 norm, the product requires applying a safety surface according to the product's free fall height.

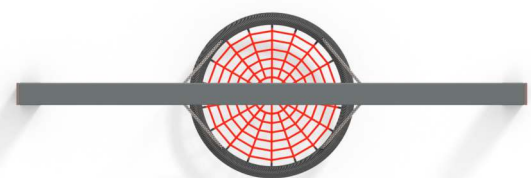

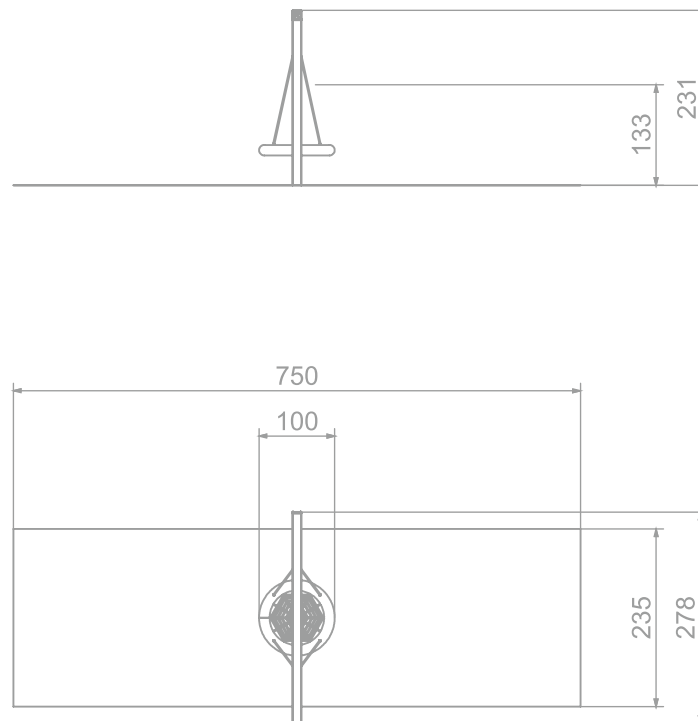

SCALE 1:100

MATERIALS:

SOLID CONSTRUCTION
MADE OF BLACK STEEL
S235JR, CLEANED THE
SANDBLASTING PROCESS

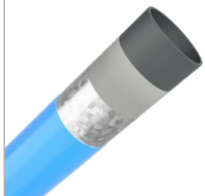

SWING SLINGS, WITH
DOUBLE BEARINGS



PLATES OF THE WALLS MADE
OF COLORFUL TRIPLE
LAYERED 15 MM HDPE
POLYETHYLENE



„BIRD NEST“ TYPE SEAT
WITH A DIAMETER OF 100 CM,
HANGED ON 6 MM STAINLESS
STEEL CHAINS



OPTIONAL:

APPROVED SEAT
– SEAT TYPE – HANGED
ON R 6 MM CHAINS
MADE OF STAINLESS STEEL
METAL FRAME COVERED
BY SOFT POLYPROPYLENE ROPE



APPROVED SEAT MADE
WITH ROTOMOULDED
METHOD, DEDICATED
FOR DISABLED USERS

